

### TECHNICAL DATA



**DRY COOLER (5) GH2490.CX D/02 V QRAFS**

Number of circuits **108**

#### PERFORMANCE (SINGLE UNIT)

Requested Capacity	<b>720,00 kW</b>	Ratio	<b>2,5 %</b>
Real Capacity	<b>737,60 kW</b>		

#### TUBE SIDE

Fluid (10)	<b>PROPYLENE GLYCOL 40%</b>		
Inlet Fluid Temp.	<b>48,0 °C</b>	Outlet Fluid Temp.	<b>42,7 °C</b>
Fluid flow rate	<b>129,00 m³/h</b>	Fluid Velocity	<b>1,7 m/s</b>
Massic Fluid Flow	<b>131084 kg/h</b>	Pressure drops	<b>42 kPa</b>

#### AIR SIDE

Inlet Air Temp [MAX]	<b>32,0 °C</b>	Outlet Air Temp.	<b>43,2 °C</b>
Inlet relative hum.	<b>50,0 %</b>	Outlet relative hum.	<b>27,1 %</b>
		Altitude	<b>0 m</b>
		ESP	<b>0,0 Pa</b>
		Flow Direction	<b>Vertical</b>
Air Flow	<b>200305 m³/h</b>	Air Velocity	<b>3,50 m/s</b>

#### FANS TECHNICAL DATA

ERP	<b>Yes</b>	UL	<b>No</b>
Fan Number	<b>8 N°</b>	Fan Diameter	<b>900 mm</b>
Phases-Voltage-Frequency	<b>3-400-50 N°/Volt/Hz</b>	Fan type	<b>34050H91ACB2</b>
Rpm [Nominal data]	<b>893 Rpm</b>	Link	<b>Delta</b>
Power x 1 [Nominal data]	<b>3600 Watt</b>	Current x 1 [Nominal data] (1)	<b>7,20 A</b>
Rpm [Working point]	<b>893 Rpm</b>	Rpm rate [working point / nominal]	<b>100 %</b>
Power x 1 [Working point]	<b>3600 Watt</b>	Current x 1 [Working point] (1)	<b>7,20 A</b>
Total Power x n° [Working point]/ [Nominal data]	<b>28800/28800 Watt</b>	Total Current x n° [Working point]/ [Nominal data]	<b>57,60/57,60 A</b>
Efficiency Energy Class:nominal calculation Water 40-35°C/Air 25°	<b>E</b>	Efficiency Energy Class:calculation on the working point	<b>E</b>

#### FANS NOISE DATA (7)

Sound Pressure Level (4) [Working point]	<b>70 dB(A)</b>	Sound Power Level (4) [Working point]	<b>102 dB(A)</b>
At the distance of	<b>10 m</b>	in accordance with EN 13487/EN ISO 3744 (7)	

#### HEAT EXCHANGER DATA (3)

Fin Material (2)	<b>Aluminium Turbo</b>	Tubes Material	<b>Copper</b>
Fin Spacing	<b>2,1 mm</b>	Internal Volume	<b>349,0 dm³</b>
Fin Thickness	<b>0,1 mm</b>	Casing material	<b>Galvanized steel painted</b>
Surface	<b>1969,0 m²</b>	Number of passes	<b>2</b>
Inlet Connection	<b>3x4"</b>	Connections	<b>Same side</b>
Outlet Connection	<b>3x4"</b>	Fluid Category	<b>Group 2</b>
Max Pressure Design	<b>10 bar</b>		

#### DIMENSIONS AND WEIGHT (3)

Length	<b>7530 mm</b>	Weight (3)	<b>1866 kg</b>
Width	<b>2400 mm</b>	Number of fixing point	<b>6</b>
Height	<b>1565 mm</b>	LDM (Approximate data)	<b>2,51 m</b>

#### SOUND POWER LEVEL

	Tot.	63Hz	125Hz	250Hz	500Hz	1kHz	2kHz	4kHz	8kHz
Δ [dB(A)]	<b>87</b>	<b>54</b>	<b>66</b>	<b>72</b>	<b>81</b>	<b>83</b>	<b>82</b>	<b>79</b>	<b>69</b>

Data refers to one fan. IMPORTANT: the tolerance in any single octave band is +/-5dB. The tolerance in the overall dB(A) level is +/- 2dB.

In case of AC fans working point is defined by fan supplier in nominal curve (delta or star). In case of EC fans is simulated on working point of unit.

### DRY COOLER (5) GH2490.CX D/02 V QRAFS

#### ACCESSORIES

CODE	DESCRIPTION	S/NS
IMB	Packing	
DIAMCOLL_SP	Special header diametre	
VENTTRI	Three phase fan 'T'	
CBLO	Wiring with electrical panel 'Q'	
RGTFDL	Phase cut speed controller (D) 'R'	
AMM_TAV	Shock absorbers Table 'A'	
FSON	Aluminium slip on flanges (one pair) 'F'	

#### WARNING

An inverter different from the one proposed by Thermokey must have omni polar sinusoidal filters, between phase and phase and phase and ground.

(\*) Attention: Please check with Thermokey the conformity of minimal operating temperature of the selected equipment (fans, cables, ...)

For any support please contact our Sales Department

Offer validity

**60 Days**

Lead time (9)

**to be defined**

Thermokey sales conditions are available on the website  
[www.thermokey.com](http://www.thermokey.com)

---

**DRY COOLER (5) GH2490.CX D/02 V QRAFS**

---

- (1) The voltage is referred to the supplier's nominal data: fans consumption may vary with the air temperature and voltage system.
- (2) The unit may not be suitable for very corrosive atmosphere. For special applications contact Thermokey. If a special fin material is selected (copper, coating), all the other materials of the unit remain standard (for detailed information please check the Technical description of the unit).
- (3) Dimensions and weight are not valid for all possible options! The overall dimensions on the data sheet relate to the units without controls / electrical panels (For more detailed information please refer to the Electrical Box Manual). In the case of horizontal air flow units the standard position of the connections is on the left looking at the finned pack.
- (4) Any noise caused by control systems, adiabatic system and so on, is not considered in the fan noise declaration. Actual values can also be subject to changes depending on the conditions of the installation.
- (5) The manual consists of 4 parts; IG = General instructions for safe use, IM = Instructions for handling and unpacking, TC = Instructions and technical specifications, IS = Specific use and maintenance instructions. If not expressly requested at the pre-Purchase Order stage, the TC and IS instructions must be downloaded by the user from [www.thermokey.com](http://www.thermokey.com) as they will not be provided in paper format. The installer is required to follow the instructions of the above manuals and of all the main electrical components' manuals (e.g. fans, pumps, regulators).
- (6) The unit is equipped with fans that follow the efficiency requirements of ERP directive 2009/125/EC
- (7) In accordance with EN 13487 the declared sound pressure level for this unit has been calculated in free-field conditions over a reflecting plane with a parallelepiped surface. With reference to ISO 3744, when the difference of measurement of the unit in on and off stage is  $\leq 6$  dB (A), the sound measurement does not reach the accuracy as required by the Directive. Background noise values lower than 30dB (A) are typical of indoor and silent environments. The declaration of the sound pressure of the unit, stated on the Thermokey data sheets, considers the background noise negligible.
- (8) S x x x x : id serial number of the combination of the standard options available on Archimede (listed and described in the ACCESSORIES section) and special on request. The code appears on the order confirmation (as a part of the model code description) and on the data plate of the unit. Note: For each range the available options are listed in the catalogue on the Table Options and Accessories. The register of combinations of options associated with the code S x x x x is available on request.
- (9) Delivery time for standard unit is considered ex works. For any special terms and conditions (ex. Large quantities, special items..) please contact Sales dept.
- (10) The standard unit is not self-draining: the choice of fluid (water / glycol) is closely related to the freezing point of the same and to the actual operating period of the unit. For a self-draining construction, please contact Thermokey for a special offer.
- (12) The dimensioning is made through a simulation of the selection program which does not take into account the influence of the installation conditions.
- (13) For the selection of the maximum operating pressure, the pressure related to the condensation temperature (i.e. middle point) is taken into account

(14) For fan units with microchannel cores, it is mandatory to respect the procedures available on ThermoKey website (Indications for the use of Tk micro cores)

(15) Fluid Group related to Directive 2014/68 / CE.

(16) The data on the fan label do not represent the worst absorption conditions.

(17) The declared performances are suitable for HVAC applications with air flow in a free field on both coil and fan sides (e.g. avoid recirculation or any element that reduces airflow) and with uniform inlet temperatures to the coil (e.g. avoid conditions on which adjacent elements cause temperature variations at the unit inlet). For other critical applications (e.g. industrial, power) please contact Thermokey.

(18) Thermokey reserves the right to change the technical data, drawings and prices of the Archimede software at any time and without prior notice. Please refer to the software release and EULA of the software in Section "?".

(19) The Archimede software is based on Refprop's latest libraries of oils, refrigerants and blends. Data updates may result in different performances of the units than those of previous releases of Archimede.

(20) Pay attention that the overall dimensions and weight of the unit equipped with EPS system, indicated in the technical sheet, refer to the model without electrical part and mounted evaporative panels, for variation of the possible option combinations please refer back to the following indications!

Take into consideration that the evaporative modules mounted on the side of the model protrude of 440mm all together on the width of the model footprint, whereas they do not affect the length and height dimensions of the model, moreover the discharging tubes mounted on the models protrude of extra 320mm all together on the width of the model. Take into consideration that the control panels and connection piping protrude depending on the selected and requested combinations of 400mm from the extremities of the model.

Consider as 60 kilos each module (per fan) the operative weight of the evaporative modules mounted with wet panels. Pay attention that in the case of non optimal maintenance of the discharging drip-trays or of the discharging line, you should consider a possible store of water in the tray and of the sole discharging pipes of EPS system of about 30 kilos per module (per fan). Consider the pre-mounted connection piping of EPS system to water supply network on the model of about 25 kilos per unit. Consider weight of the possible pre-mounted control electrical panel of the EPS system on the model of about 35 kilos per unit.

Model: GH2490.CX D/02 V QRAFS

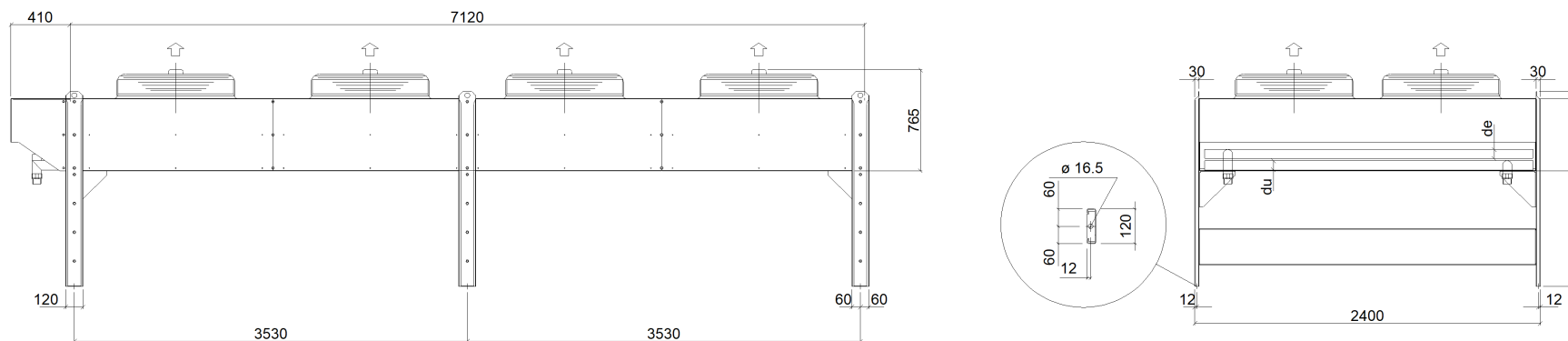

Attention: Drawing and dimensions not valid for all accessory options!

The overall dimensions on the datasheet refer only to the unit without regulation (For more detailed information refer to Electrical box Manual). In the units with horizontal air flow the standard position of the connections is left looking at the finned pack (right looking at the fans).

CONNECTIONS	
Inlet Connections	3x4"
Outlet Connections	3x4"

**ThermoKey**  
 Heat Exchange Solutions  
 Via dell'industria 1  
 33061 Rivarotta di Rivignano di Teor (UD) - ITALY  
 Tel.: +39/0432772300 Fax.: +39/0432779734

Company  
 Attention of  
 City  
 Telephone  
 Fax

Date 19/8/2019  
 Sw Version 190418  
 Offer - Rev. 00  
 Reference  
 Position

---

**DRY COOLER (5) GH2490.CX D/02 V QRAFS**

---

**LIQUID COOLERS:**

Quality standard ISO 9001

Applied Directives:

2014/68/EU Pressure Equipment Directive (PED)

2014/35/EU Low Voltage Directive (LVD)

2014/30/EU Electromagnetic Compatibility Directive (EMC)

2006/42/EC Machinery Directive (MD)

2011/65/UE Directive on the restriction of the use of certain hazardous substances in electrical and electronic equipments (RoHS)

**FINNED PACK HEAT EXCHANGER**

Optimised geometries for use with mixtures of water or water-glycol and pure, made with tube and fin materials designed to achieve the best performances. The coil is tested at a pressure of 17 bar. For test purposes all circuits are supplied with vent valves and drain valves. Coverplates and side plates made with customised material and painting depending on heat exchanger application. Fin spacing from 1.8 to 4 mm based on materials/applications (2.1 mm by default). Upon request, the whole finned pack can undergo different types of treatments/coatings depending on the application.

Triangular geometry (42 x 36.4 mm) with backflow air-refrigerant circuits in order to optimise the thermodynamic capacity. Heat exchange tubes in smooth copper (Ø 16 mm - 5/8").

Aluminium louvered fins

**CASING**

The casing is made of hot-dip galvanised steel elements painted with a RAL 7035 powder coating to ensure excellent resistance to corrosion in the main applications. The units have been designed to be highly modular. The internal construction allows great air distribution using any type of controller thanks to inner partition walls which make each single fan air flow independent. The bends are protected by suitable panels. Components painting is done after any production operation so that protection against corrosion is guaranteed on all parts. All unpainted exposed components are made with materials having a level of resistance to corrosion either equal or superior to that of the painted casing. The casing is in compliance with corrosivity category C4-L (pursuant to standard UNI EN ISO 12944). Upon request, the casing can be manufactured following special painting, RAL and stainless steel specifications depending on the required application.

**PACKAGING**

Wooden crate packaging with protective film for transportation. The unit is delivered in vertical position (horizontal air flow) supplied with feet. Upon request, the units can be supplied with dedicated packaging for special shipments (e.g. container, etc.).

**FANS**

All fan units manufactured by Thermokey are fit with axial type fans featuring a motor with an external rotor directly built-in the axial propeller to create a compact, maintenance-free fan. Optimised efficiency and minimised noise level thanks to the fan blades aerodynamic design. Protective grids in compliance with EN 294. All the fans have to meet the requirements of balance quality grade Q 6.3 as prescribed in DIN ISO 1940. Motor protection class IP54. Windings in thermodynamic capacity class F, pursuant to DIN EN 60 034-1. The noise levels in use are those declared by the fan manufacturer according to DIN 24166, precision grade 3, measured according to DIN 45635. The sound pressure level declared for this unit has been calculated in free field conditions on a parallelepiped reflecting reference surface in compliance with standard EN 13487. Upon request, fans with special features can be supplied (voltage, frequency, corrosion category, etc.).

Two-speed AC fans (delta-star), ideal for ongoing control of the speed rotation with the help of a cut phase, step or inverter speed controller. Three-phase motor(s) 400V-3ph+PE-50 Hz. Temperature range between -40.0 °C and 60.0 °C (average value depending on the type of fan and on the fan power supply). Thermal contacts are built in the winding.

## HYDRAULIC CONNECTIONS

Copper headers. Flanged connections with aluminium slip-on flange PN10 UNI6089 and copper flare fitting. All dry coolers with flanged connections are supplied with a pre-assembled pressure gauge to check the heat exchanger pre-charge pressure (pre-charged with nitrogen to a pressure of 3 bar).

## ACCESSORIES

### A – SHOCK ABSORBERS

Shock absorbing elastic bases for industrial machineries having a galvanised steel body and NBR elastomer element.

### R - PHASE CUT CONTROLLER FOR "RGM300" AC FANS

Controller R is a multifunction and multiple-input unit for the regulation of speed of asynchronous three-phase motors installed on axial fans. This device works as a voltage controller according to the cut phase principle (control over the three phases) in order to continuously increase and reduce the value of voltage supplied to three-phase AC motors mounted on the fan units (condensers, liquid coolers and unit coolers). Power supply: 3ph+PE 400Vac  $\pm$  20 % - 50/60Hz (other voltages upon request). Available controller sizes: 12A-20A-26A-40A-60A. Working temperatures: -20 °C  $\div$  50 °C. Plastic UV-resistant junction box with protection class IP55. Input from external signal or transducer: 0-20mA, 4-20mA, 0-5V, 0-10V. RS485 interface for MODBUS networking. Auxiliary contacts - contacts available: S1 - direct mode (by default with NO contact) - reverse (NC contact); SP - Selection of setpoints 1 or 2 (SP1 by default with NO contact; SP2 with NC contact); S5 - night speed limitation (by default OFF with NO contact; ON with NC contact); S2 - controller ON-OFF (by default ON with NO contact; OFF with NC contact); TK: contact for connection of the thermal motor protection (by default FANS ON with NC contact; FANS OFF with NO contact). Contact for RL1 general alarm relay. PID regulation principle. Optional proportional mode. Min. and Max. fan speed setting. Possibility to disable 3 different fan speed ranges bypassing work areas characterised by high sound disturbance. Display showing the main operating parameters. LED indicator of controller status. Controller mounted, wired and programmed according to the calculation board of the fan unit. NTC temperature probe(s) (10kOhm) fitted with silicone cable and stainless steel terminal. Storage temperature -20 °C  $\div$  70 °C. Pressure transducer(s) 4-20mA fitted with silicone cable (2 wires), 7/16" 20UNF (8-28V) -25 °C  $\div$  80°C (0-30bar (0-50bar upon request)).

### Q - THREE-PHASE ELECTRICAL PANEL FOR 400V-3-50HZ AC FANS

Description: plastic UV-resistant box, protection class IP55. Electrical cables suitable for outdoor installation (connection of phases and thermal contacts from fans). Working temperatures : -25°C/40 °C. Power supply: 3~400V / 50Hz + PE. Main switch. Green warning light to signal system is powered. Transformer 400V/24V for auxiliary contacts. Fuse protector for main power line. Terminal block for connection of controllers R + P + Z + G. Contacts for remote ON/OFF control. Contacts for additional thermostat. Free contacts for fan alarm warning devices. Execution in compliance with CE regulations. Panel mounted and wired.